

Safety Shut-off Valves series VSB and VSA

Gas safety solenoid shut-off valve series VSB and VSA, approved according to the norm EN 161 with CE product identification and manufactured according to regulation EU 2016/426, are suitable for the automatic control of gases belonging to the first, second and third family.

On request there are versions for biogas and air. These valves, normally closed for continuous and cyclic operation, open by powering the coil and close quickly when there is no tension.



TECHNICAL FEATURES

Valve body	Brass OT-58 and die-cast aluminium
Pipe connections for valves with brass body	Rp 3/8, Rp 1/2, Rp 3/4 according to EN 10226
Pipe connections for valves with aluminium body	Rp 1/2 ÷ 2 according to EN10226
Pipe flanged connections for valves with aluminium body	DN 65 ÷ 200 PN16 according to ISO 7005
Inlet pressure	200 mbar, 360 mbar and 500 mbar
Opening/closing time on quick version	< 1 second
Standard supply voltage	230V ac, 110V ac, 24V and 12V ac and dc
Frequency	50 ÷ 60 Hz, 50 Hz per 12V and 24V ac
Enclosure	IP 65 - IEC 529
Supply voltage tolerance	-15% - +10%
Duty cycle	Continuous
Ambient temperature	-20 / +60 °C

FEATURES

- Class A, Group 2 according to EN161
- Electromagnetic Compatibility – Directive 2004/108/CE
- Low voltage – Directive 2006/95/CE
- SIL 2 for single solenoid valves, if 2 valves are installed in series with tightness control, they reach SIL 3
- Quick and slow opening and quick closing
- Quiet operation
- Poliammidic resin encapsulated coils and metallic frame for flanged bodies
- Pressure test points at inlet by both sides
- Accessories on request: by-pass, limit switch, manual max. flow adjustment

SHUT-OFF VALVES SERIES VSB...

VSB = Safety shut-off valve in brass



Operation

- R** = Quick
- RP** = Quick with max. flow adjustment

Max. pressure

2 = 200 mbar

Nominal diameter

- 10** = Rp 3/8
- 15** = Rp 1/2
- 20** = Rp 3/4

Supply voltage

- A** = 24V ac/50 Hz
- B** = 110V ac/50 - 60 Hz
- C** = 230V ac/50 - 60 Hz
- E** = 24V dc
- F** = 12V dc
- G** = 12V ac / 50 Hz

VSB

R

2

15

C

FLOW CHART

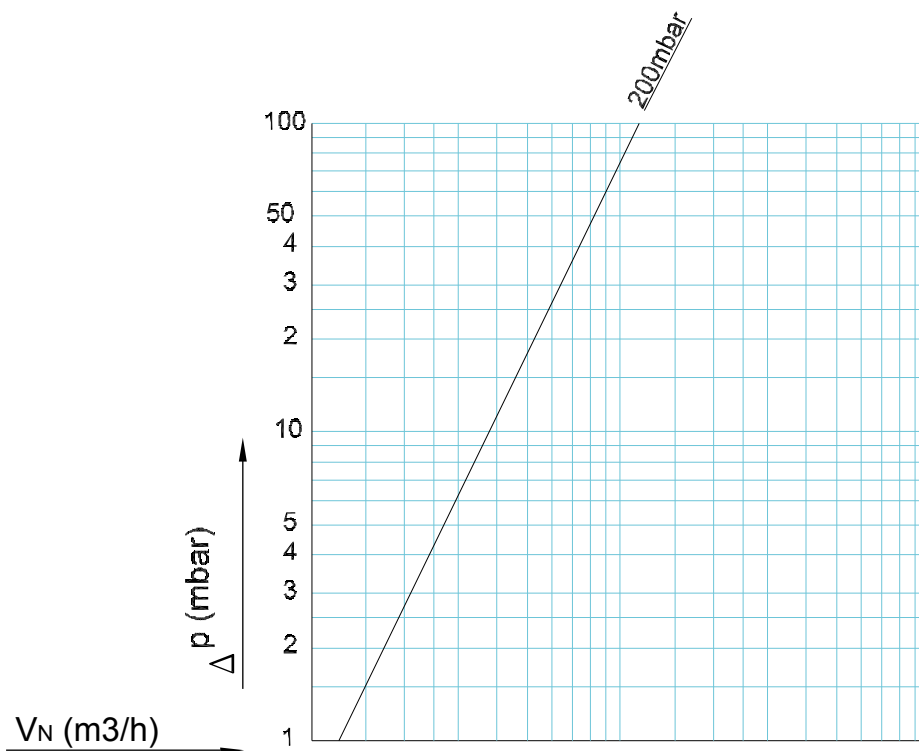

Aria	dv=1	1 2 3 4 5 6 8 10 2 3 4 5 6 8 100
Air	dv=1	1 2 3 4 5 6 8 10 2 3 4 5 6 8 100
Metano	dv=0,64	1 2 3 4 5 6 8 10 2 3 4 5 6 8 100
Methane	dv=0,64	1 2 3 4 5 6 8 10 2 3 4 5 6 8 100
Gas di città	dv=0,45	1 2 3 4 5 6 8 10 2 3 4 5 6 8 100
Town gas	dv=0,45	1 2 3 4 5 6 8 10 2 3 4 5 6 8 100
Propano	dv=1,56	1 2 3 4 5 6 8 10 2 3 4 5 6 8
Propane	dv=1,56	1 2 3 4 5 6 8 10 2 3 4 5 6 8
Butano	dv=2,09	1 2 3 4 5 6 8 10 2 3 4 5 6
Butane	dv=2,09	1 2 3 4 5 6 8 10 2 3 4 5 6
G.P.L.	dv=1,70	1 2 3 4 5 6 8 10 2 3 4 5 6
L.G.P.	dv=1,70	1 2 3 4 5 6 8 10 2 3 4 5 6

SHUT-OFF VALVES SERIES VSA... Rp 1/2 - 3/4 - 1

VSA = Safety shut-off valve in aluminium



Operation

- R** = Quick
- RP** = Quick with max. flow adjustment
- L** = Slow
- LP** = Slow with max flow adjustment
- LSP** = Slow with max flow adjustment + rapid stroke

Max. pressure

- 2** = 200 mbar
- 5** = 500 mbar

Nominal diameter

- 15** = Rp 1/2
- 20** = Rp 3/4
- 25** = Rp 1

Supply voltage

- A** = 24V ac/50 Hz
- B** = 110V ac/50 - 60 Hz
- C** = 230V ac/50 - 60 Hz
- E** = 24V dc
- F** = 12V dc
- G** = 12V ac/ 50 Hz

Other accessories

- BP** = By-pass
- I** = signal lamp by valve feeding (in the connector)
- M** = limit micro-switch
- F** = Flanged (only for Rp 1)
- BK** = Black cataphoresis

VSA **R** **2** **15** **C** **BK**

FLOW CHART

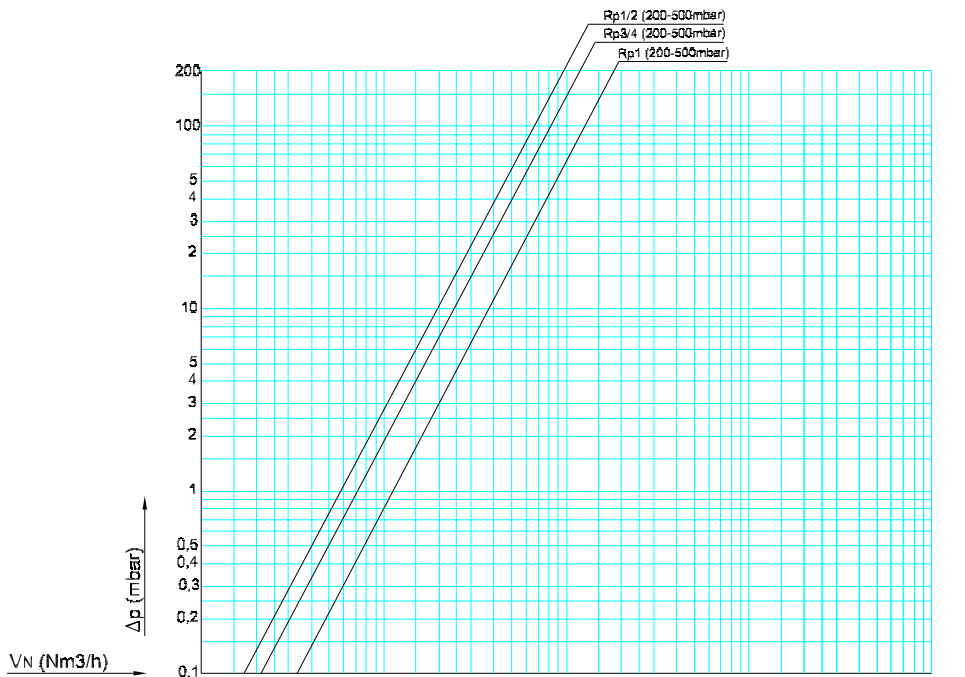

Aria	dv=1	1 2 3 4 5 6 7 8 10 2 3 4 5 6 8 100 2 3 4 5 6 8 1000 2 3 4 5 6 8 10000
Air	dv=1	1 2 3 4 5 6 7 8 10 2 3 4 5 6 8 100 2 3 4 5 6 8 1000 2 3 4 5 6 8 10000
Metano	dv=0,64	1 2 3 4 5 6 7 8 10 2 3 4 5 6 8 100 2 3 4 5 6 8 1000 2 3 4 5 6 8 10000
Methane	dv=0,64	1 2 3 4 5 6 7 8 10 2 3 4 5 6 8 100 2 3 4 5 6 8 1000 2 3 4 5 6 8 10000
Gas di città	dv=0,46	1 2 3 4 5 6 7 8 10 2 3 4 5 6 8 100 2 3 4 5 6 8 1000 2 3 4 5 6 8 10000
Town gas	dv=0,46	1 2 3 4 5 6 7 8 10 2 3 4 5 6 8 100 2 3 4 5 6 8 1000 2 3 4 5 6 8 10000
Propano	dv=1,56	1 2 3 4 5 6 7 8 10 2 3 4 5 6 8 100 2 3 4 5 6 8 1000 2 3 4 5 6 8 10000
Propane	dv=1,56	1 2 3 4 5 6 7 8 10 2 3 4 5 6 8 100 2 3 4 5 6 8 1000 2 3 4 5 6 8 10000
Butano	dv=2,08	1 2 3 4 5 6 7 8 10 2 3 4 5 6 8 100 2 3 4 5 6 8 1000 2 3 4 5 6 8 10000
Butane	dv=2,08	1 2 3 4 5 6 7 8 10 2 3 4 5 6 8 100 2 3 4 5 6 8 1000 2 3 4 5 6 8 10000
G.P.L.	dv=1,70	1 2 3 4 5 6 7 8 10 2 3 4 5 6 8 100 2 3 4 5 6 8 1000 2 3 4 5 6 8 10000
L.P.G.	dv=1,70	1 2 3 4 5 6 7 8 10 2 3 4 5 6 8 100 2 3 4 5 6 8 1000 2 3 4 5 6 8 10000

SHUT-OFF VALVES SERIES VSA... Rp 1.1/4 - 1.1/2 - 2



VSA = Safety shut-off valve in aluminium

Operation

- R** = Quick
- RP** = Quick with max. flow adjustment
- L** = Slow
- LP** = Slow with max flow adjustment
- LSP** = Slow with max flow adjustment + rapid stroke

Max. pressure

- 2** = 200 mbar
- 3** = 360 mbar
- 5** = 500 mbar

Nominal diameter

- 32** = Rp 1.1/4
- 40** = Rp 1.1/2
- 50** = Rp 2

Supply voltage

- A** = 24V ac 50 Hz
- B** = 110V ac 50-60 Hz
- C** = 230V ac 50-60 Hz
- E** = 24V dc

Other accessories

- BP** = By-pass
- I** = signal lamp by valve feeding (in the connector)
- M** = limit micro-switch
- F** = Flanged
- BK** = Black cataphoresis

VSA

R

3

40

E

BK

FLOW CHART

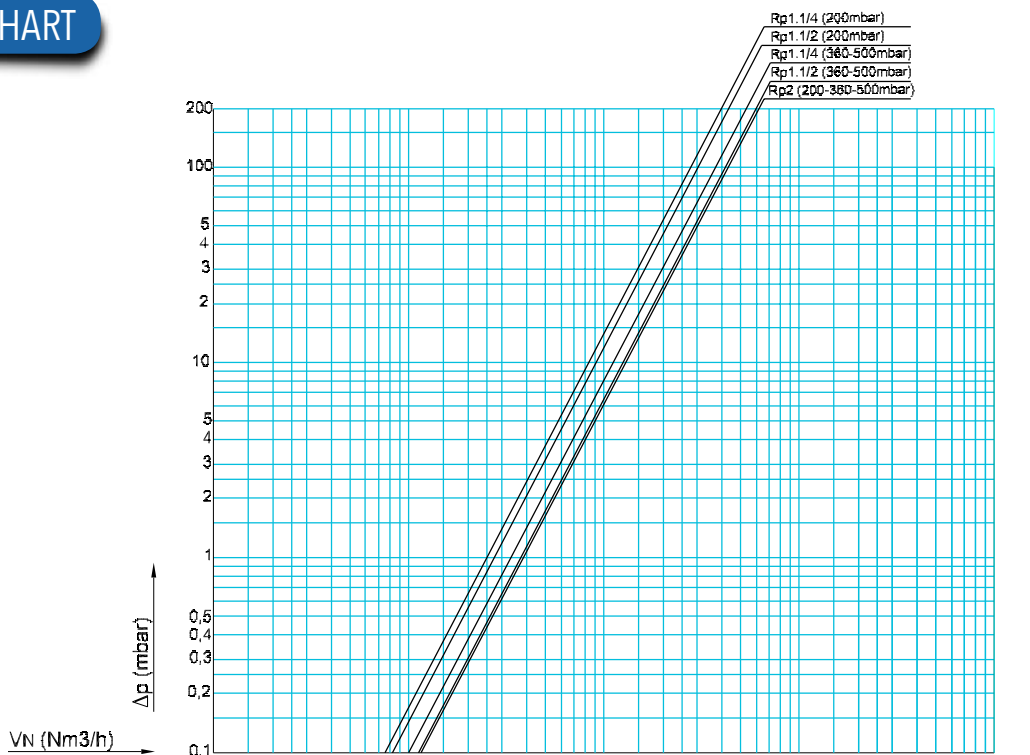

Aria	dv=1	1 2 3 4 5 6 8 10 2 3 4 5 6 8 100 2 3 4 5 6 8 1000 2 3 4 5 6 8 10000
Metano Methane	dv=0,64	4 2 3 4 5 6 8 10 2 3 4 5 6 8 100 2 3 4 5 6 8 1000 2 3 4 5 6 8 10000
Gas di città Town gas	dv=0,46	1 2 3 4 5 6 8 10 2 3 4 5 6 8 100 2 3 4 5 6 8 1000 2 3 4 5 6 8 10000
Propano Propane	dv=1,56	1 2 3 4 5 6 8 10 2 3 4 5 6 8 100 2 3 4 5 6 8 1000 2 3 4 5 6 8
Butano Butane	dv=2,09	1 2 3 4 5 6 8 10 2 3 4 5 6 8 100 2 3 4 5 6 8 1000 2 3 4 5 6 8
G.P.L. L.P.G.	dv=1,70	1 2 3 4 5 6 8 10 2 3 4 5 6 8 100 2 3 4 5 6 8 1000 2 3 4 5 6 8

SHUT-OFF VALVES SERIES VSA... FLANGED DN65÷DN200

VSA = Safety shut-off valve in aluminium

Operation

- R** = Quick
- RP** = Quick with max. flow adjustment
- L** = Slow
- LP** = Slow with max. flow adjustment
- LSP** = Slow with max. flow adjustment + rapid stroke

Max. pressure

3 = 360 mbar

Nominal diameter

65 = DN 65 **125** = DN 125
80 = DN 80 **150** = DN 150
100 = DN 100 **200** = DN 200

Supply voltage

A = 24V ac 50 Hz
B = 110V ac 50-60 Hz
C = 230V ac 50-60 Hz
E = 24V dc

Other accessories

- BP** = By-pass
- I** = signal lamp by valve feeding (in the connector)
- M** = limit micro-switch
- BK** = Black cataphoresis



VSA R 3 80 E BK

FLOW CHART

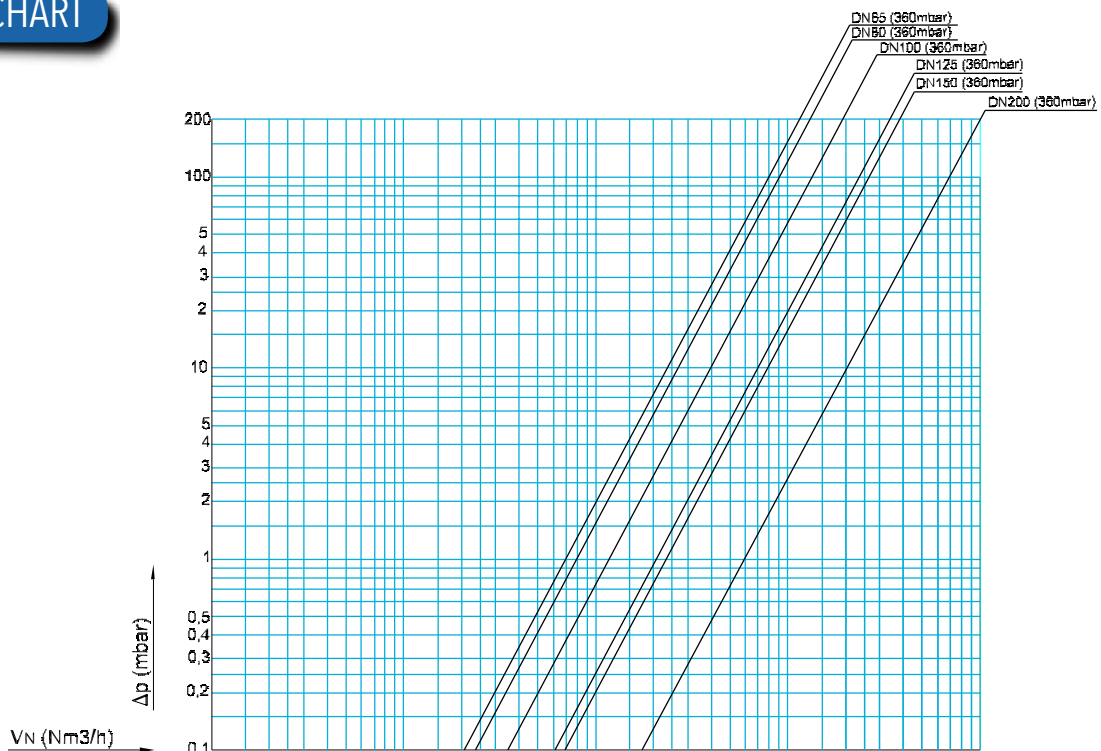

Aria Air	dv=1	1 2 3 4 5 6 7 8 10 2 3 4 5 6 8 100 2 3 4 5 6 8 1000 2 3 4 5 6 8 10000
Metano Methane	dv=0,64	1 2 3 4 5 6 8 10 2 3 4 5 6 8 100 2 3 4 5 6 8 1000 2 3 4 5 6 8 10000
Gas di città Town gas	dv=0,45	1 2 3 4 5 6 8 10 2 3 4 5 6 8 100 2 3 4 5 6 8 1000 2 3 4 5 6 8 10000
Propano Propane	dv=1,56	1 2 3 4 5 6 8 10 2 3 4 5 6 8 100 2 3 4 5 6 8 1000 2 3 4 5 6 8 10000
Butano Butane	dv=2,09	1 2 3 4 5 6 8 10 2 3 4 5 6 8 100 2 3 4 5 6 8 1000 2 3 4 5 6 8 10000
G.P.L. L.P.G.	dv=1,70	1 2 3 4 5 6 8 10 2 3 4 5 6 8 100 2 3 4 5 6 8 1000 2 3 4 5 6 8 10000

SERIES VSB... QUICK OPENING

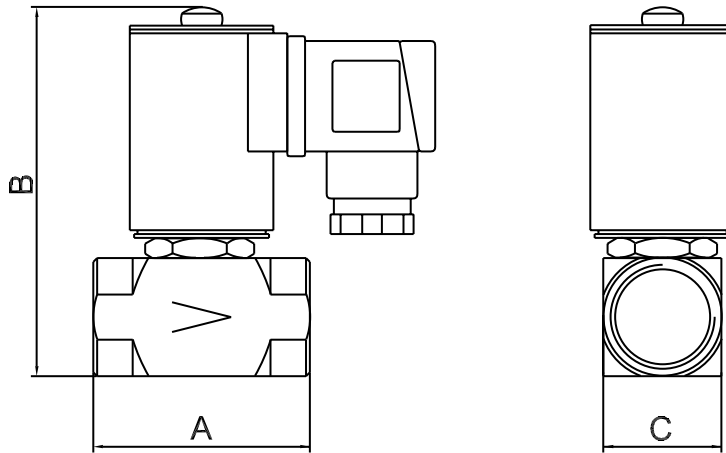

An energy saving connector Green for valuable reduction of energy consumption is also available (3 VA).

Pipe Rp	Max pressure (mbar)	Rating at 230 V (VA)	Rating at 230 V with Green conn. (VA)	Dimensions (mm)			Weight (Kg)	Model
				A	B	C		
3/8	200	9	3	55	90,5	37	0,6	VSBRP210C...
1/2	200	9	3	55	90,5	37	0,6	VSBRP215C...
3/4	200	9	3	55	90,5	37	0,6	VSBRP220C...

SERIES VSA..... QUICK / SLOW OPENING THREADED Rp 1/2, 3/4, 1

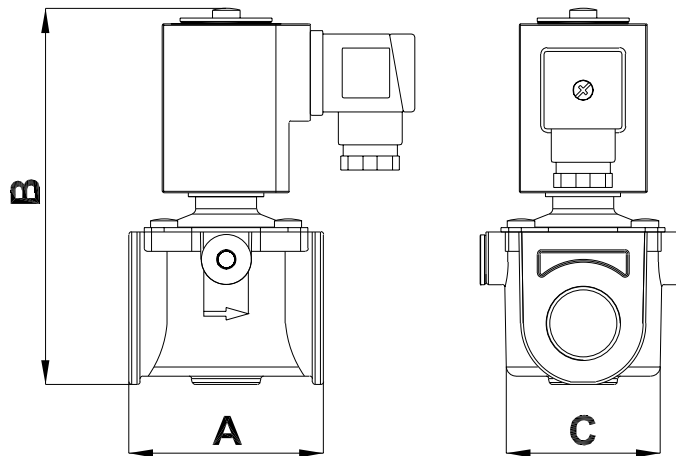

Pipe Rp	Max pressure (mbar)	Rating at 230 V (VA)	Dimensions (mm)					Weight (Kg)	Model
			A	B			C		
				R	RP	L - LP/LSP			
1/2	200	18	75	135	150	200	74	0,85	VSA 215C...
	500	18						VSA 515C...	
3/4	200	18	75	135	150	200	74	0,85	VSA 220C...
	500	18						VSA 520C...	
1	200	18	75	135	150	200	74	0,80	VSA 225C...
	500	18						VSA 525C...	

SERIES VSA... QUICK / SLOW OPENING THREADED Rp 1.1/4, 1.1/2, 2

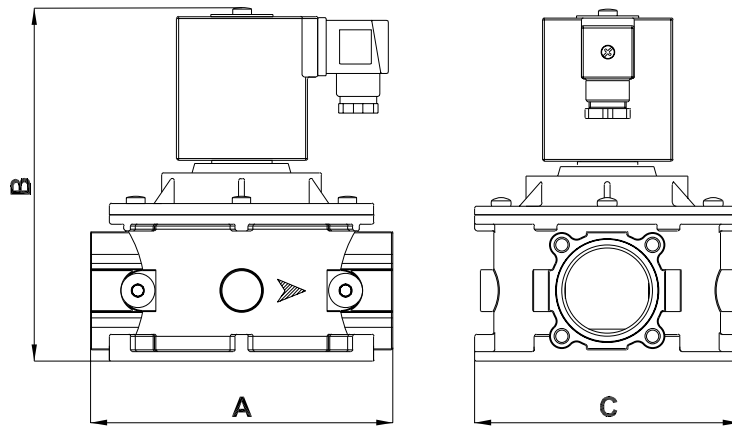

Pipe Rp	Max pressure (mbar)	Rating at 230 V (VA)	Dimensions (mm)					Weight (Kg)	Model	
			A	B						C
				R	RP	L	LP/LSP			
1.1/4	200	89 / 25	160	185	200	260	260	140	3,4	VSA 232C...
	360			210	225	285	285		3,6	VSA 332C...
	500									
1.1/2	200	89 / 25	160	185	200	260	260	140	3,4	VSA 240C...
	360			210	225	285	285		3,6	VSA 340C...
	500			210	285	285	285			
2	200	89 / 25	160	210	225	288	288	140	3,6	VSA 250C.....
	360			235	235	295	295			VSA 350C...
	500			235	235	295	295			

SERIES VSA... QUICK / SLOW OPENING FLANGED

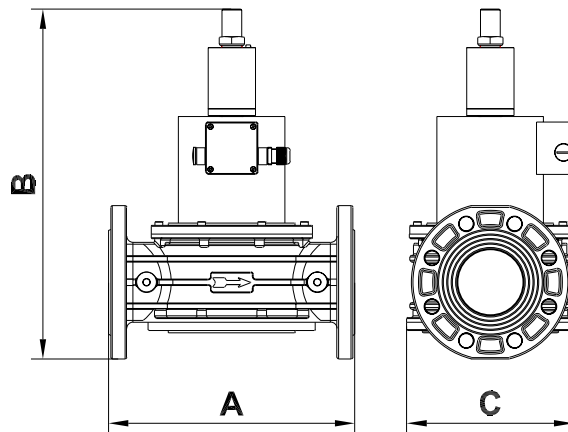

Pipe DN	Max pressure (mbar)	Rating at 230 V (VA)	Dimensions (mm)					Weight (Kg)	Model	
			A	B						C
				R	RP	L	LP/LSP			
65	360	105 / 29	290	321	321	432	480	211	17	VSA 365C...
80			310	328	328	439	486	211	17,60	VSA 380C...
100		124 / 36	350	389	389	500	547	254	29,60	VSA 3100C...
125			480	570	570	681	728	322	34,00	VSA 3125C...
150			480	570	570	681	728	552	45,00	VSA 3150C...
200		47 / 5	600*	----	920	1162	1162	----	101,00	VSA 3200C...

* Opening time 13 seconds ± 20%.

WIRING INSTRUCTIONS

Installation, adjustment and maintenance of the valve must be carried out exclusively by skilled and authorized service technicians

1. Before electric wiring, check that the main voltage matches with the power supply voltage stated on the product label.
2. Disconnect power before wiring.
3. By wiring connector, use terminals and cables as reported in the Instruction leaflet in the package.
4. Connect the power supply to terminals 1 and 2 and the ground wire to terminal .
5. Using energy saving Green connector with 12 and 24 Vdc comply with polarity.

INSTALLATION AND OPERATING INSTRUCTIONS

1. Make sure that all operating data indicated on the safety shut-off valve label correspond to those of the system.
2. Before installing the safety shut-off valve, quit the gas supply and make sure that the pipeline is free from impurities. The pipeline must be vibration-free.
3. The flow direction indicated by the arrow on the valve body must be respected, facing towards the user appliance. The safety valve can be installed either horizontally or vertically, provided that the coil is not turned downwards.
4. When installing the safety shut-off valve in pipework do not use the coil as a lever, but use the correct wrench.
5. The sealing material must be applied to the external thread of the pipeline only and not to the internal thread of the safety shut-off valve.

ADJUSTMENT OF FLOW RATE - OPENING TIME AND RAPID STROKE

QUICK OPENING

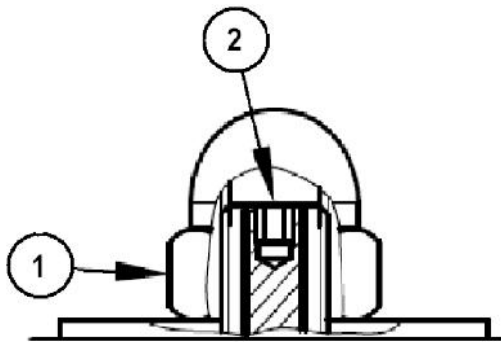



1. Coil fastening nut
2. Flow rate adjustment

Unscrew the nut and spin the internal screw clockwise  to reduce and counter clockwise  to increase the flow rate.

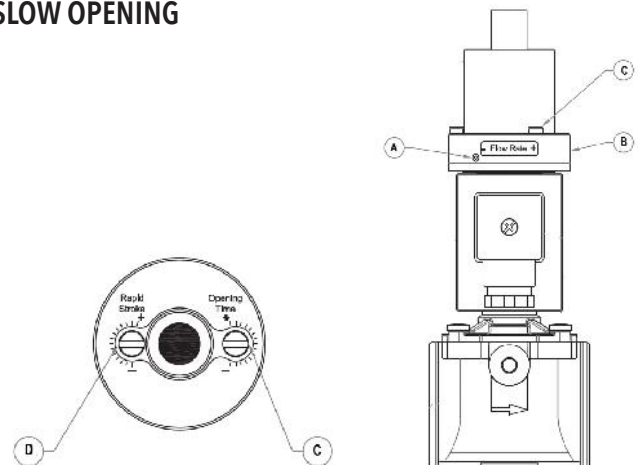
SLOW OPENING



1. Flow rate adjustment. Loosen screw A and rotate cylinder B to the desired position. Tighten screw A to fix the position.
2. Opening time adjustment. Turn screw C clockwise  to reduce the opening time or turn counter clockwise  to increase values.
3. Rapid stroke adjustment.

All the reported data are subject to be changed without notice.

form210309