

Linear control valves series MPV

The control valves of the newly conceived MPV series are certified according to EN 13611 Norms to meet requirements in industrial combustion systems. They are particularly suitable for the proportional adjustment of combustion gas flows of the first, second and third family and of air. The electric motor is unipolar and bidirectional, with high static and maintaining torque for 3-position-control, or proportional with analogic input control signal: current or voltage change.

A cylindrical plug, linear featured, regulates the flow rate of the valve. By cylinder rotation, the orifice size of the plug changes with, adjusting the flow linearly. Three different orifice sizes are available according to the operating conditions.



TECHNICAL FEATURES

Construction	Die-cast aluminium	Voltage	230V, 115V, 24V ac/50-60 Hz
Rating feature	Linear	Nominal load	4 - 7 VA
Control ratio	>25:1	Input signal	4÷20 mA or 0÷10V dc
Operating pressure	max 500 mbar	Output signal (on request)	4÷20 mA or 0÷10V dc
Opening/closing time	15, 30, 60 s. per 90°	Duty cycle	Continuous 100%
Ambient temperature	-10 ÷ +60 °C	Auxiliary end switches rating	0,5 A / 48V dc and ac
Connections	Rp 1 according to ISO7-1	Enclosure	IP 54 IEC 529, IP 65 <small>on request</small>
Group	2	Cable gland	2 x M20x1,5

FEATURES

- Sturdy, compact construction, especially suitable for industrial application
- Installation in any position
- Minimum leakage with valve in closed position
- Max flow adjustment
- Connecting lever to be installed between the valve and the actuator
- On request adjustable by-pass Ø 4 mm for minimum flow adjustment
- Manual/automatic control station
- 2 adjustable auxiliary microswitches
- Wide range of accessories on request:
 - 1 o 2 feedback potentiometer: from 150 ohm to 5 kohm
 - Mechanical position indicator
 - Input signal 4÷20 mA or 0÷10V dc
 - Output signal 0÷10V dc

FLOW CHART

- 25
 - 19
 - 12
- Sede
Seat

- Reg. portata tutto aperto
Flow adj. open
- Reg. portata tutto chiuso
Flow adj. close

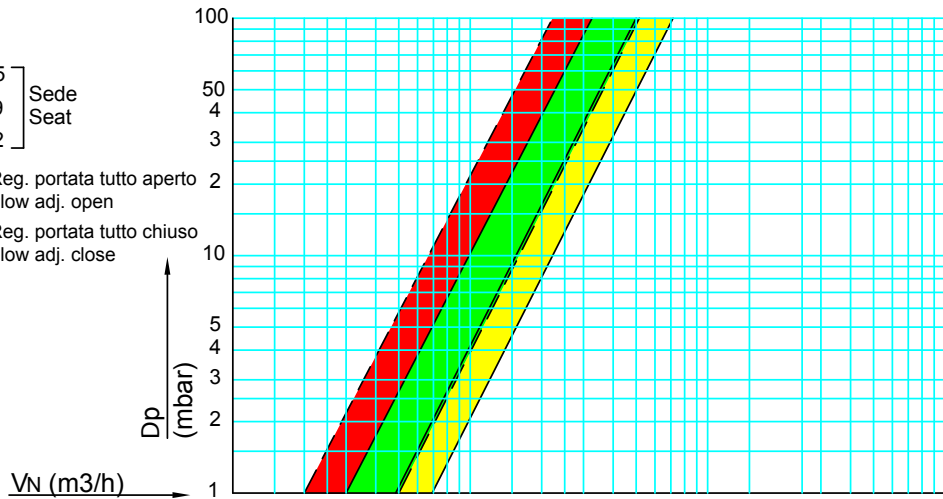

Aria Air	dv=1	
Metano Methane	dv=0,64	
Gas di citta' Town gas	dv=0,45	
Propano Propane	dv=1,56	
Butano Butane	dv=2,09	
G.P.L. L.P.G.	dv=1,70	

MODELS

S1= Valve body

Orifice

- 12 = 119 mm²
- 19 = 187 mm²
- 25 = 282 mm²

Accessories

- BP = adjustable by-pass 4 Ø mm
- P = max flow adjustment
- P5 = Shaped adaptor with lever LTF112F20

S1 19 P5

AB1= Actuator

Supply voltage

- A = 24V ac ± 10% / 50 - 60Hz
- B = 115V ac + 6% - 10% / 50 - 60Hz
- C = 230V ac + 6% - 10% / 50 - 60Hz
- B/A = with transformer 115V/24V ac~ + 6% - 10% / 50 - 60Hz
- C/A = with transformer 230V/24V ac~ + 6% - 10% / 50 - 60Hz

Rotation time for 90° at 50 Hz

- 1 = 15 s
- 2 = 30 s
- 3 = 60 s

Feedback Potentiometer. (not to be supplied with incorporated transformer)

- 00 = not foreseen
- 13 = 1 kohm
- 15 = 2,5 kohm
- 16 = 5 kohm (Spectrol)
- 18 = 1 kohm (Spectrol)
- 21 = n.2 pot. 150 ohm
- 23 = n.2 pot. 1 kohm
- 25 = n.2 pot. 2,5 kohm

Auxiliary Microswitches

- 0 = not foreseen (only for version 230V-60 sec rotation)
- 2 = 2 (standard)

Accessories

- S = Manual/Automatic control station
- O = Position indicator on the top cover
- R1 = Relay control (ON/OFF)
- Z = Enclosure IP65

Control signal

- E1 = Input 0 ÷ 10V cc, Output 0 ÷ 10V cc
- E2 = Input 0 ÷ 10V cc o 4 ÷ 20 mA, Output 0 ÷ 10V cc
- E4 = Input 0 ÷ 10V cc
- E5 = Input 4 ÷ 20 mA
- E7 = Input 4 ÷ 20 mA, Output 0 ÷ 10V cc
- E8 = Input 4 ÷ 20 mA, Output 4 ÷ 20 mA

AB1 C/A 3 00 2 S E5

ELECTRIC FLOATING VERSION

SCHEMA S4
FORM 04/14
+AUTO/MAN

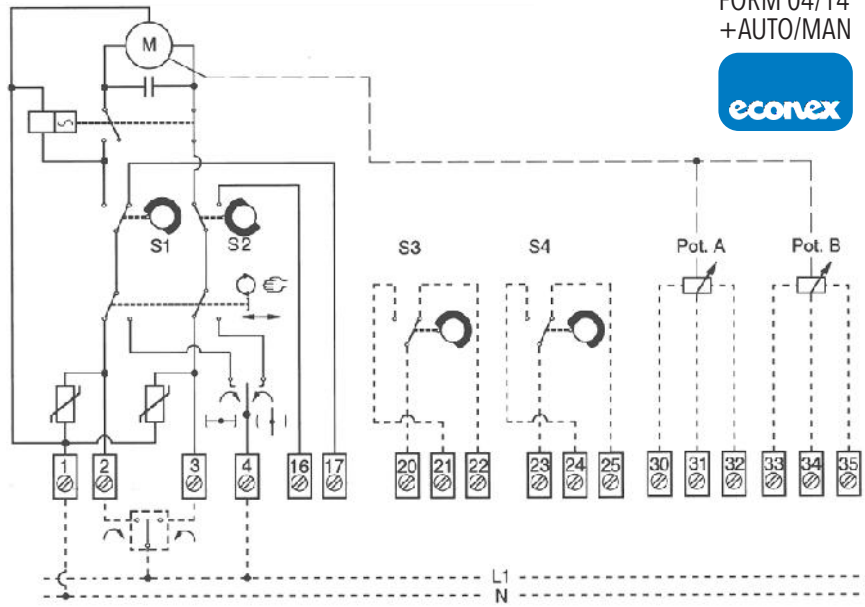

ELECTRONIC ANALOGIC VERSION 24V

SCHEMA GT 79
FORM 03/14

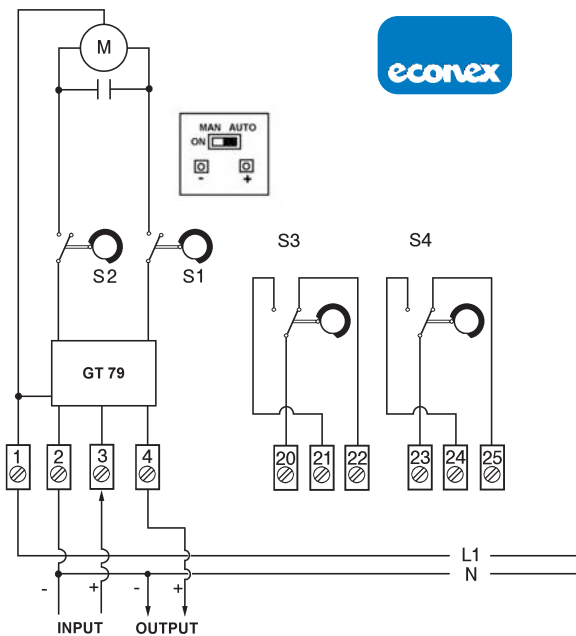

ELECTRONIC ANALOGIC VERSION 115 - 230V

SCHEMA GT 79
FORM 04/14

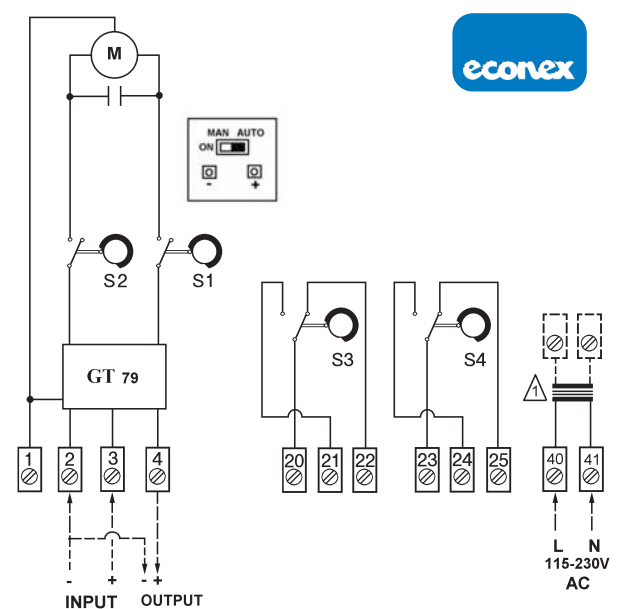

⚠ PROTEZIONE ESTERNA >15VA

CAM ADJUSTMENT

For cam adjustment, the proper lever supplied with the gear motor equipment is to be used. Use the lever from the right side, introducing the pin into one of the bores on the sides of the blue cam and lever it to the desired position. If the blue cam is in a behind position, use the lever on its curved side to move the blue cam to a more suitable position to perform adjustment. Adjustment is possible in both directions along the whole rotation of the cam shaft. Remove the lever before servicing.

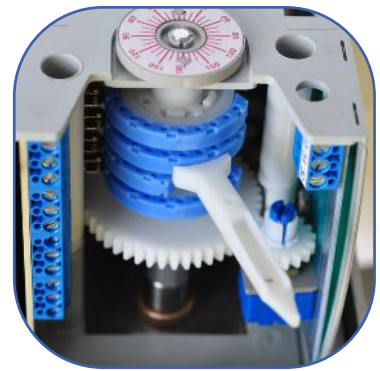

DIMENSIONS

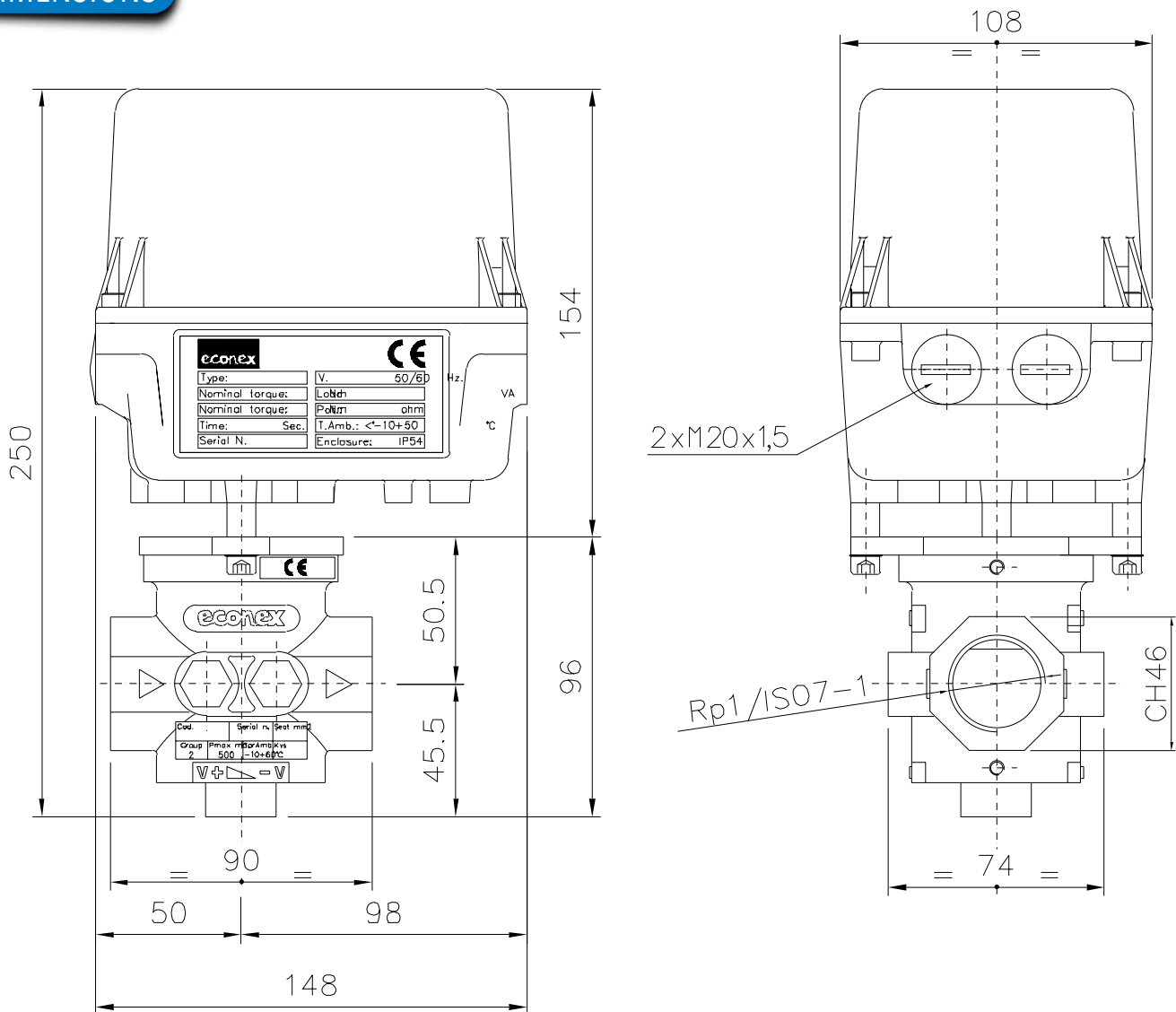

All the reported data are subject to be changed without notice.

form240528

econex

Econex s.r.l. - Via A. Einstein, 2 - 20057 Assago (MI) - Italy

Tel. +39 0289502912 - Fax +39 028463084 - www.econex.it - info@econex.it